

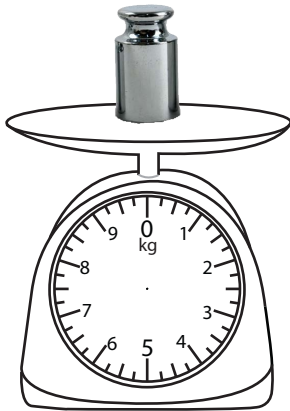

# Мерење маса

**1** Нацртај стрелка на вагата за да ја покажува точната маса.

1) 5 kg



2) 850 g

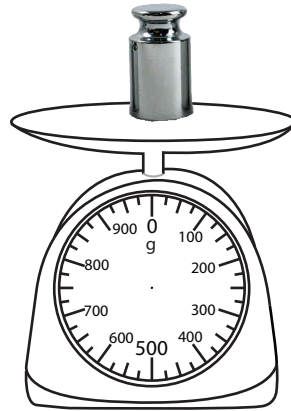

3) 2 kg 500 g

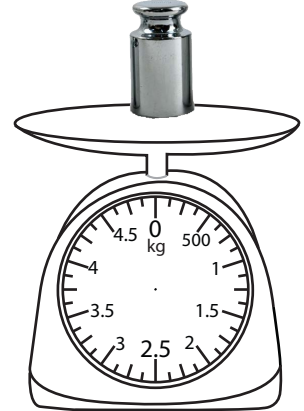

4) 1.5 kg

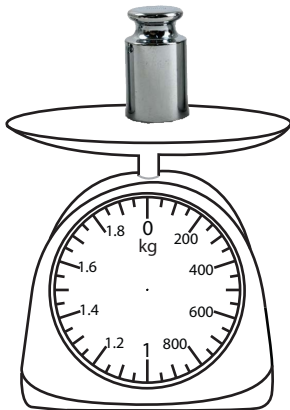

5) 8000 g

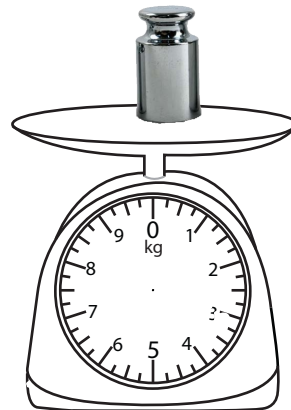

6) 4 kg

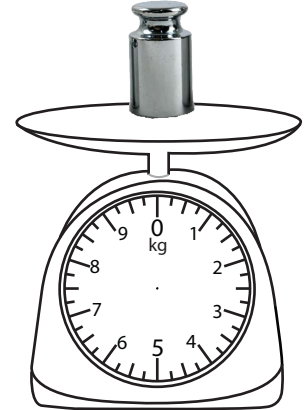

7) 150 g

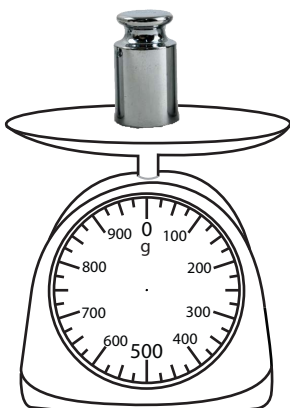

8) 9 kg

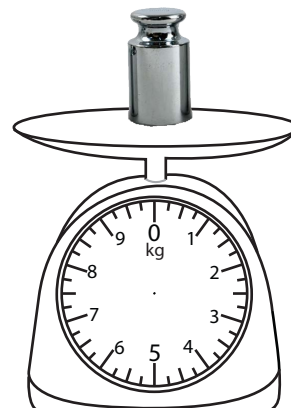

9) 3.5 kg

